

## AQP85B4-XXX

### 100Gb/s QSFP28 Active Optical Cable

#### PRODUCT FEATURES

- Full duplex 4 channel 850nm parallel active optical cable
- Up to 27.952Gbps Data rate per channel
- Maximum link length of 150m links on OM3 multimode fiber
- High Reliability 850nm VCSEL technology
- Electrically hot-pluggable
- Case operating temperature range:0°C to 70°C
- Power dissipation < 2.5 W per cable end



#### APPLICATIONS

- 100G Ethernet
- Infiniband QDR
- Fiber channel
- HPC Interconnections

#### STANDARD

- Compliant to QSFP28 MSA
- RoHS Compliant.

## Product selection

Part Number	Product description
AQP85B4-XXX	XXX=different cable lengths on OM3 Multimode Fiber (MMF), max 150m –Note
<b>XXX</b>	<b>cable lengths on OM3 Multimode Fiber (MMF)</b>
003	3m
005	5m
007	7m
010	10m

Note:

More detail product selection and cable lengths, please contact sales.

## I Absolute Maximum Ratings

Parameter	Symbol	Min.	Typ.	Max.	Unit	Note
Storage Temperature	Ts	-40	-	85	°C	
Relative Humidity	RH	5	-	95	%	
Power Supply Voltage	VCC	-0.3	-	4	V	
Signal Input Voltage		Vcc-0.3	-	Vcc+0.3	V	

## II Recommended Operating Conditions

Parameter	Symbol	Min.	Typ.	Max.	Unit	Note
Case Operating Temperature	Tcase	0	-	70	°C	Without air flow
Power Supply Voltage	VCC	3.14	3.3	3.46	V	
Power Supply Current	ICC	-		750	mA	per cable end
Data Rate	BR		25.78125		Gbps	Each channel

### III General Product Characteristics

Parameter	Value	Unit	Notes
Module Form Factor	QSFP28		
Number of Lanes	4 Tx /Rx		
Maximum Aggregate Data Rate	111.8	Gb/s	
Maximum Data Rate per Lane	27.952	Gb/s	
Standard Cable Lengths	3, 5, 7, 10	meters	Other lengths, please contact sales
Protocols Supported	Typical applications include Infiniband, Fiber Channel, 100G Ethernet		
Electrical Interface and Pin-out	38-pin edge connector		Pin-out as defined by the QSFP28 MSA
Standard Optical Cable Type	Multimode ribbon fiber cable assembly, riser-rated		
Maximum Power Consumption per End	2.5	W	
Management Interface	Serial, I2C-based, 400 kHz maximum frequency		As defined by the QSFP28 MSA

### IV. High-speed Electrical Characteristics per Lane

Parameter-Inputs	Symbol	Min	Typ	Max	Unit	NOTE		
<b>Input electrical specifications (per Lane)</b>								
Differential Voltage pk-pk				900	mV			
Common Mode Noise RMS				17.5	mV			
Differential Termination Resistance Mismatch				10	%			
Differential Return Loss	SDD22	Per OIF CEI-28G-VSR and CAUI-4 requirements						
Common Mode to Differential conversion and Differential to Common Mode Conversion	SDC22,							
	SCD22							
Common Mode Return Loss	SCC22							
Transition Time, 20 to 80%	Tr, Tf	10			ps			
Common Mode Voltage	Vcm	-0.3		2.8	V			
Eye Width at 1E-15 probability	EW15	0.46			UI			
Eye Height at 1E-15 probability	EH15	94			mV			

Output electrical specifications (per Lane)						
Differential Voltage pk-pk				900	mV	
Common Mode Voltage	Vcm	-350		2850	mV	
Common Mode Noise RMS				17.5	mV	
Differential Termination Resistance Mismatch				10	%	
Differential Return Loss	SDD22	Per OIF CEI-28G-VSR and CAUI-4 requirements			dB	
Common Mode to Differential conversion and Differential to Common Mode Conversion	SDC22, SCD22				dB	
					dB	
Common Mode Return Loss	SCC22				dB	
Output Rise and Fall time (20% to 80%)	tRH, tFH	9.5			ps	
Vertical Eye Closure	VEC			5.5	dB	
Eye Width at 1E-15 probability	EW15	0.57			UI	

## V. Pin Assignment

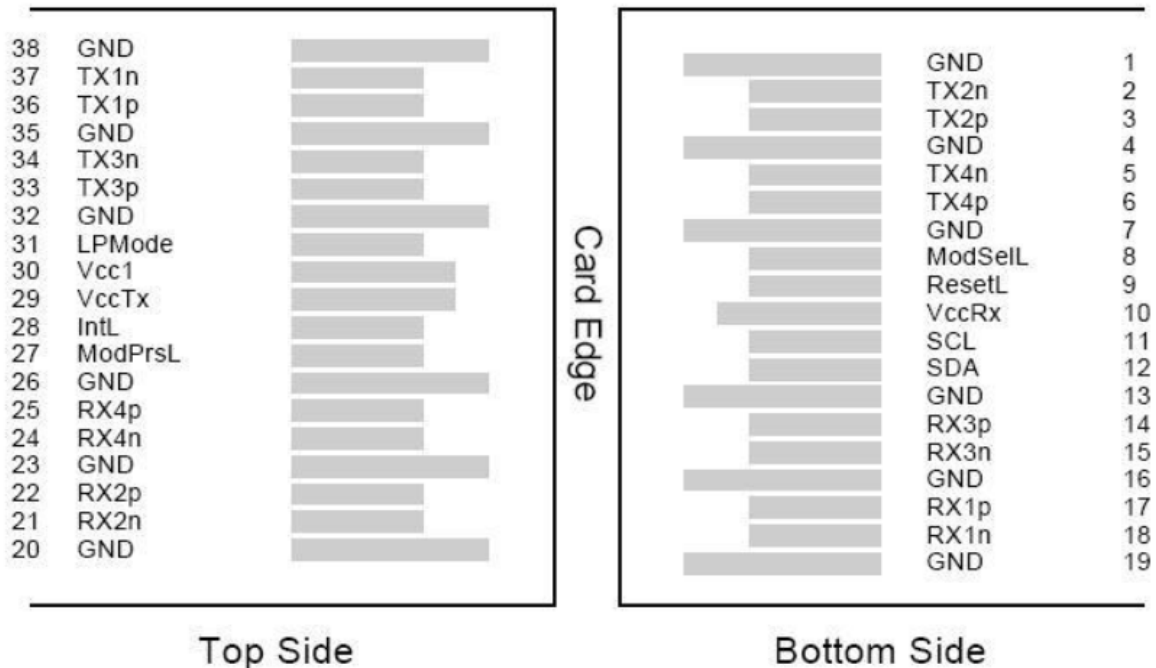

Figure 4---Pin out of Connector Block on Host Board

Pin	Symbol	Name/Description	NOTE
1	GND	Transmitter Ground (Common with Receiver Ground)	1
2	Tx2n	Transmitter Inverted Data Input	
3	Tx2p	Transmitter Non-Inverted Data output	
4	GND	Transmitter Ground (Common with Receiver Ground)	1
5	Tx4n	Transmitter Inverted Data Input	
6	Tx4p	Transmitter Non-Inverted Data output	
7	GND	Transmitter Ground (Common with Receiver Ground)	1
8	ModSelL	Module Select	
9	ResetL	Module Reset	
10	VccRx	3.3V Power Supply Receiver	2
11	SCL	2-Wire serial Interface Clock	
12	SDA	2-Wire serial Interface Data	
13	GND	Transmitter Ground (Common with Receiver Ground)	
14	Rx3p	Receiver Non-Inverted Data Output	
15	Rx3n	Receiver Inverted Data Output	
16	GND	Transmitter Ground (Common with Receiver Ground)	1
17	Rx1p	Receiver Non-Inverted Data Output	
18	Rx1n	Receiver Inverted Data Output	
19	GND	Transmitter Ground (Common with Receiver Ground)	1
20	GND	Transmitter Ground (Common with Receiver Ground)	1
21	Rx2n	Receiver Inverted Data Output	
22	Rx2p	Receiver Non-Inverted Data Output	
23	GND	Transmitter Ground (Common with Receiver Ground)	1
24	Rx4n	Receiver Inverted Data Output	1
25	Rx4p	Receiver Non-Inverted Data Output	
26	GND	Transmitter Ground (Common with Receiver Ground)	1
27	ModPrsl	Module Present	
28	IntL	Interrupt	
29	VccTx	3.3V power supply transmitter	2
30	Vcc1	3.3V power supply	2
31	LPMODE	Low Power Mode, not connect	
32	GND	Transmitter Ground (Common with Receiver Ground)	1
33	Tx3p	Transmitter Non-Inverted Data Input	
34	Tx3n	Transmitter Inverted Data Output	
35	GND	Transmitter Ground (Common with Receiver Ground)	1
36	Tx1p	Transmitter Non-Inverted Data Input	
37	Tx1n	Transmitter Inverted Data Output	
38	GND	Transmitter Ground (Common with Receiver Ground)	1

**Notes:**

- GND is the symbol for signal and supply (power) common for QSFP+ modules. All are common within the QSFP+ module and all module voltages are referenced to this potential unless otherwise noted. Connect these directly to the host board signal common ground plane.
- VccRx, Vcc1 and VccTx are the receiving and transmission power suppliers and shall be applied

concurrently. Recommended host board power supply filtering is shown below. Vcc Rx, Vcc1 and Vcc Tx may be internally connected within the QSFP28 transceiver module in any combination. The connector pins are each rated for a maximum current of 500mA.

## VI. Host - Transceiver Interface Block Diagram

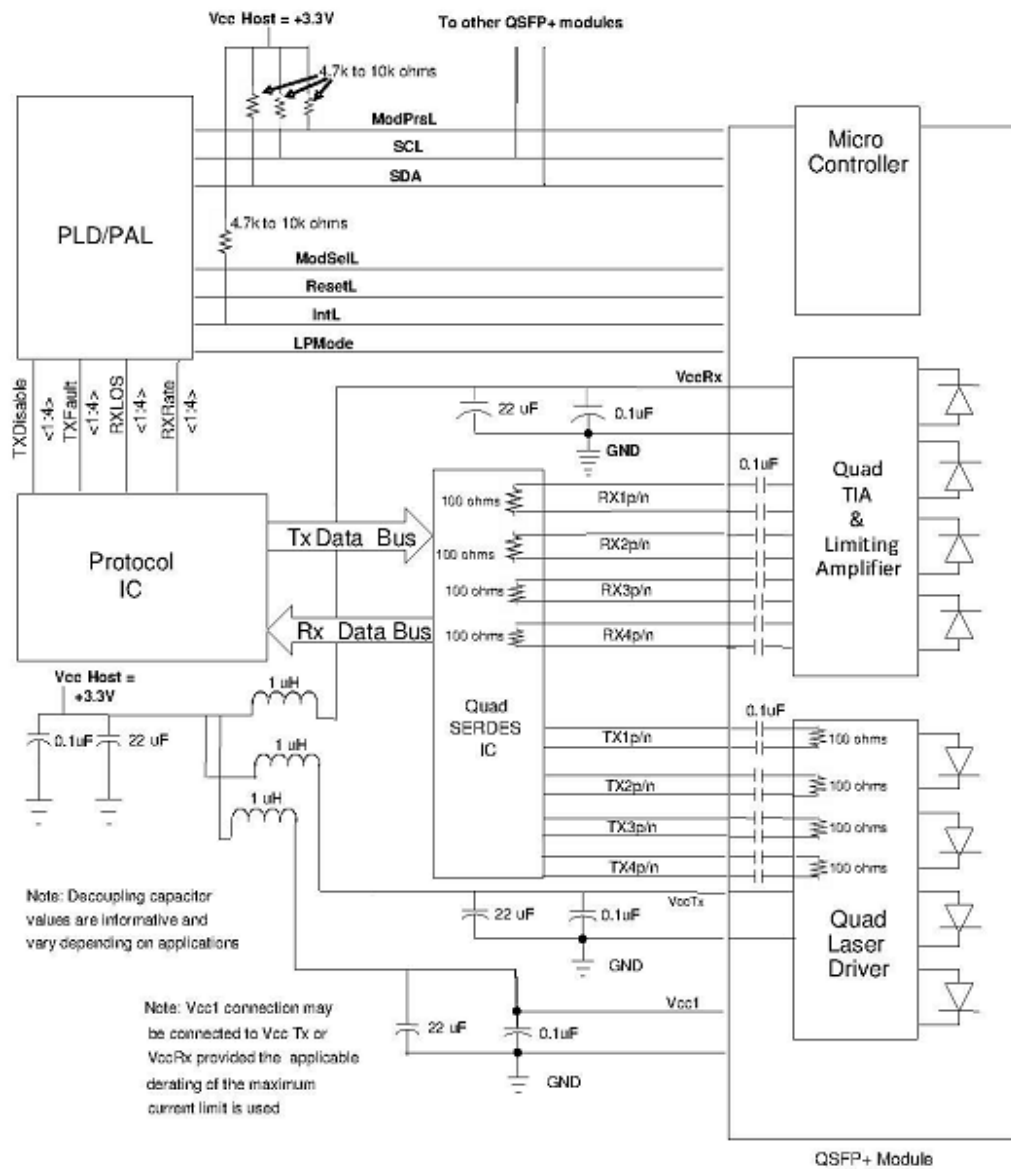

## VII. Outline Dimensions

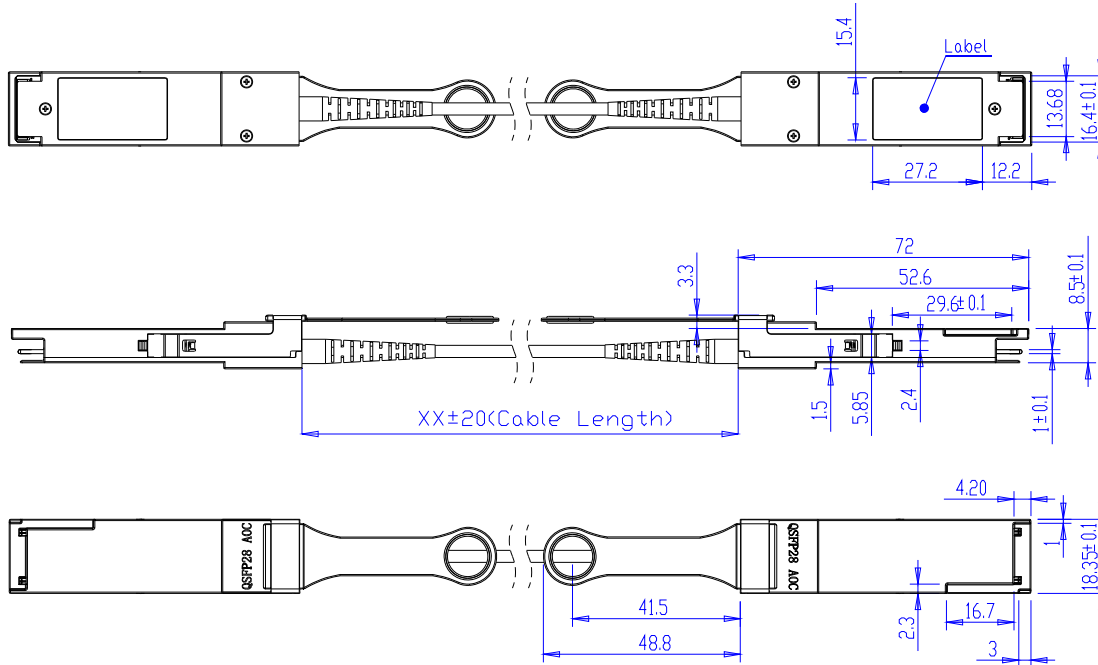

## Appendix A. Document Revision

Version No.	Date	Description
Preliminary	2016-06-17	Preliminary datasheet
1.0	2017-10-9	Update module picture